

User manual for:

Manufacturer	Model
Interlevin	ECF98

Uploaded: Feb 2016

Interlevin Refrigeration Ltd
 West Meadow Rise
 Castle Donington
 Derby
 DE74 2HL

Sales: 01332 850090
Parts: 01332 850190
Service: 01332 850064
Email: trade.sales@interlevin.co.uk
Web: www.interlevin.co.uk

ECF98

Instruction Manual



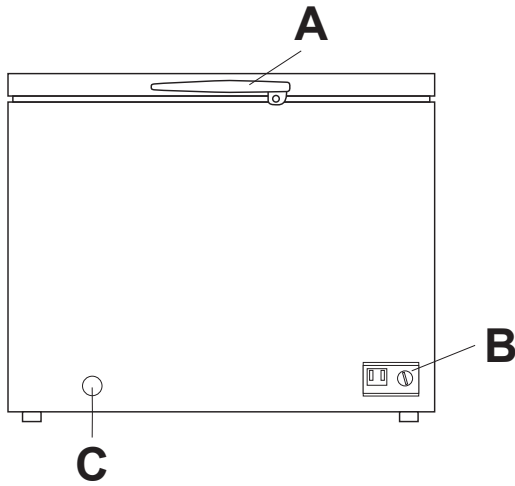

- A Lock
- B Controlpanel
- C Drain

Starting

- 1 Fully unpack the appliance.
- 2 Remove the polystyrene parts in the compressor chamber (if supplied).
- 3 Remove documents and any accessories from the inside of the appliance.
- 4 Clean the interior with a mixture of lukewarm water and vinegar, and dry thoroughly with a cloth.
- 5 Close the appliance.
- 6 Insert the plug in the socket
- 7 Switch on the appliance by turning the temperature control to the right (For the time being, turn the controller fully to the right to Max position). (green and red lights go on).
- 8 Do not open the appliance any more for about 4 hours respectively as long as the red light is on, to allow the temperature in the inner compartment to drop to the necessary level.
- 9 You can now fill the appliance with any amount of deep frozen food (purchased ready frozen goods)

Important!

Do not store any bottles containing liquids. Liquid expands when frozen and the bottle can explode. Never keep containers with explosive substances (gas lighters, petrol, ether and the like) in the freezer compartment of the appliance.

When storing ready frozen food, you must observe the manufacturer's instructions on the food packaging.

Deep frozen ice-cream and ice lollies must be eaten only a few minutes after being taken from the appliance to avoid injury to lips and tongue (danger of skin detachment). For the same reason, avoid touching the inner walls with wet hands. We advise

you to use defrosted or slightly frozen products within short time. As a rule, such products are not suitable for re-freezing.

Indicator-lights

If your appliance is equipped with indicator-lights, the following guide explains what is meant by each light up:

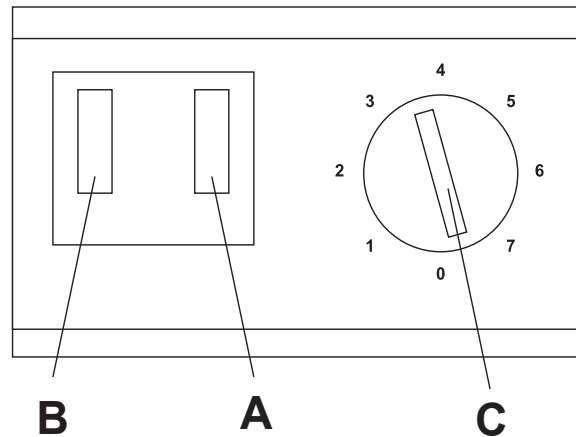

- A Green = Control lamp, indicate power on the appliance.
- B Red = Alarm

The green control light must always be on when the appliance is connected to power and switched on. It is very important to pay attention to this, because in the event of a power failure.

If the red indicator-light goes on, there may be several reasons for this, namely:

- First start-up of appliance
- Restart after defrosting
- Filling freezer with fresh food

Connection to power supply

Your appliance must be connected to a power socket with grounded connection, which is conform to the respective standards and has been installed by an authorised specialist.

Before you connect the plug of the appliance with the power socket, make absolutely sure that the voltage (V) on the appliance's data-plate corresponds with that of your mains.

If the voltage differs, notify the after-sales-service or your dealer immediately, and do not on any account connect the appliance to the mains.

Interior light

(not provided in all models)

A switch is built into appliances equipped with lighting.

When the appliance is opened the light goes on automatically and switches off automatically when closed. The lamp is protected with a transparent cover.

Strictly use 15 W max. replacement bulbs.

Transport and installation

- 1 Place on level floor and remove the bottom packing, in order to decrease the shock and noise.

The angle between the compartment body and ground should be no more than 45°

- 2 Enough space should be left between the freezer and the wall for ventilation.
- 3 Place the freezer away from heat source and do not expose to direct sunshine.
- 4 Do not install where there is moisture or where it can easily be splashed by water.
- 5 Do not place the freezer in environment prone to freezing.
- 6 The appliance should not be used in open air and should not be exposed to rain.

Adjustment and running

The storing temperature can be adjusted by the thermostat of the compartment. The thermostat should be adjusted according to different environment temperature and the food by rotating the knob of the thermostat. The knob rotates clockwise from "1" to "7" (or direction arc) and the inside temperature turns down in summer (anti-clockwise rotation) and up in winter (clockwise rotation). It is usually fixed to a certain point before leaving the factory. Do not adjust too often or touch the other parts.

Trial running

Plug in and wait. The marked drop in temperature within half an hour indicates that the freezer works properly. The compressor should be left to run for a period of time (6 hours in summer 4 hours in winter) before putting the food in.

Important: Escaping refrigerant can injure your eyes.

In the event of eye contact with the refrigerant, wash your eyes instantly under plenty of running water and call/consult an eye specialist immediately.

KLIMATE CLASSES

Apparatet skal opstilles indendørs på et tørt og fungerer bedst, hvis det står et sted, hvor omgivelsernes temperatur svarer til den klimaklasse, der er angivet på apparates typeskilt.

These temperatures should not be exceeded! The climate category for your particular appliance is marked on the rating plate.

The categories are: name of climate category suitable room temperatures

Clima Classes	Room temperature
N	from +16°C to +32°C
N-ST	from +16°C to +38°C
N-T	from +16°C to +43°C
SN	from +10°C to +32°C
SN-ST	from +10°C to +38°C
SN-T	from +10°C to +43°C
ST	from +18°C to +38°C
T	from +18°C to +43°C

Rating plate

The rating plate (with technical data) is located on the housing at the rear of the appliance.

Take a note of the technical data

Copy the technical data from the rating plate to here so that it is at any time readily available, without having to move the appliance.

Normal operation sounds

In order to maintain a constant product temperature, the motor starts at regular intervals. It sounds it makes are ordinary operation sounds, and they will automatically shorten as soon as the product has reached the desired temperature. This includes the following sounds:

Minor errors/disturbances

Errors may occur with the use of the product. Before contacting the service department, please first check whether you can solve them using the following instructions:

Hum

Comes from the engine. This hum may sometimes be stronger, such as when the engine starts.

Gurgling sounds or slight hum

Comes from the coolant which circulates in the product.

Click

There is small click each time the electronics card starts or stops the engine.

Light background noise

If the refrigerator has a fan (depending on model), the air that circulates inside the product may create a light background noise

Freezing / storage of fresh food

Almost all fresh products are suitable for freezing and storage in the appliance.

For the most common of these products, we provide a table with instructions on acceptable storage times and the most suitable packing material.

Label the fresh products clearly as they are not easy to identify when deep frozen in transparent freezer-bags.

We advise you to use commercially available labels for frozen foods.

Pack fresh products in portions suitable for your household to prevent defrosting of quantities that are too large for consumption in one day in your household.

Label the portions with at least the following information:

- Product name (e.g. beef fillet)
- Weight of portion
- Quantity (total of pieces)
- Freezing date
- Use by date (consumption date)

Then continue as follows

- 1 We recommend you place fresh foods in the bottom of the freezer. This is the coldest part.

Avoid to put fresh foods directly in contact with deep frozen food. Deep frozen food could defrost and may not outlast the foreseen storage time.

- 2 Fill in within 24 hours, only the quantities of fresh food that are suitable for the freezing capacity of your appliance. See information on the rating plate (XX kg/24h).
- 3 After 24 hours, shift deep-frozen goods from the freezer bottom or the pre-freeze shelf to a hung basket so that the pre-freeze shelf or freezer bottom are available for freezing additional fresh foods.
- 4 Set the temperature control to one of the appliance's relevant filling capacities.
- 5 Keep the temperature in the storage shelf under control, preferably by placing a thermometer with a scale range of up to -26°C .

The storage temperature must always be at least -18°C .

Refilling of fresh food (not frozen)

Make sure that you refill fresh food, in quantities adequate to the freezing capacity (XXkg/24h) earliest 24 hours after the previous filling. (do not exceed maximum stacking height)

Maximum stacking height

To ensure correct storage of frozen food, never fill the storage compartment up to the edge. Always allow space between the lid and the frozen foods. Note the stacking marks affixed by the manufacturer. (as far as available)

Set the temperature control strictly according to the filling capacity.

To save energy when operating in normal ambient temperature ($+18$ to $+22^{\circ}\text{C}$).

Storage time

The storage time for purchased deep-frozen products varies and depends on the type of product and its packaging. Therefore, strictly observe the producer's instructions on the packaging.

After being defrosted, food must be consumed immediately but latest within the next 24 hours.

Precautions and advice

- Whenever cleaning or defrosting, remove the power plug.
- After closing the freezer lid, do not open it immediately and do not force it open under any circumstances. Any vacuum remaining on the seal is released after about 1 or 2 minutes, so that the lid can be opened normally once again.
- To prevent condensation and ice forming, allow cooked food to cool down to ambient temperature before closing the lid of the dish and before storage.
- Leave the freezer lid open as briefly as possible to avoid waste of energy and to prevent an excessive amount of ice forming in the appliance.
- If the red indicator-light goes on unexpectedly or stays on for a long period, do not open the lid on any account and take the appropriate measures immediately

- Do not use a screwdriver or other metal objects to remove the layer of ice. The interior walls are very delicate and will not tolerate any sharp edges. Use only plastic or wooden scrapers.

Cleaning and maintenance

For the upkeep of the external appearance of your appliance, now and again clean with furniture polish or other enamel protecting product (never, on any account, use it in the inside. Clean the seal with warm water now and again without using any cleaning product.

If your appliance has a condenser in the rear inside, from time to time remove dirt and dust. Dust and dirt impede release of heat from the inner compartment and considerably increases consumption of energy. For best results, use a light brush or duster to remove dust from the condenser on the rear wall.

If you leave your appliance out of use for an extended period (e.g. when on holidays), leave it open to prevent odours building up inside. For appliances with locks: when the chest lid is open, always set the lock in "closed" position and keep the key well away from small children to prevent accidents.

When ice and frost layers form on the inner walls up to a certain thickness, they act as an insulation element and prevent the coldness being released from the inner walls.

They must be removed from time to time.

To remove ice from the inner walls, use a plastic or wood scraper without sharp edges.

Cover the frozen food with a cloth which aids to collect the scraped ice and enables a simple removal.

Defrosting

Under normal conditions (3 to 4 openings per day) the freezer must be defrosted once or twice a year (more often in other cases).

Danger warning: Never use electrical appliances to defrost the chest freezer, e.g. hair dryer, fan heater, or devices with a naked flame (e.g. candles).

Plastic in the inner compartment can melt and escaping gas can be ignited by sparks or naked flames.

Proceed as follows:

- Provide a suitable non-metallic container (plastic container or wash-basket).
- Make absolutely sure that you remove the plug from the power socket.
- Dry your hands thoroughly to prevent skin damage by contact with ice (it is advisable to use gloves).
- Remove all frozen food from the freezer, roll it firmly in newspaper, put it into the container, place the container in a cool, dry room.
- Cover up the container all around with a thick blanket.
- Lift the separator (e) (not all models are equipped) upwards out of the guide-rail of the freezer.
- Use the divider (so far as provided) as a defrosting dish and push it on the side under the freezer – where the defrosting water drain-plug is located.

- Pull the plug (as far as provided) out of the freezer bottom.
- As previously described, scrape the thickest ice carefully from the freezer inside and put it into the kitchen sink. for defrosting.
- If necessary, speed up defrosting by placing a large pot of warm (not too hot) water on the freezer bottom.
- In freezers not provided with a drain-plug, continuously wipe up the water with a sponge.
- Thoroughly clean the inside. Rinse it with a mixture of warm water and vinegar, thereafter rinse with clear water.
- Wipe the freezer with an absorbent cloth thoroughly dry and allow to air for about 3 to 4 minutes.
- Replace the drain-plug (if provided)
- Empty the dry defrosting water dish (if provided) and slide it as separator into the guide rails of the freezer.
- Close the chest and plug it back into the socket.
- Now refill the frozen food – the oldest items at the top. To prevent frosted food from defrosting, carry out steps from 1 to 17 within max. two hours.
- When the red lamp goes off, reset the temperature control to a as per the filling capacity suitable storage temperature.

TROUBLE SHOOTING:

The design and production comply with the relative security standard of China. If you find

it does not work as usual, please examine and handle it according to the following table first. If the situation does not improve, you must contact our after-sale service center.

Resolving faults on your own

If you suspect any fault, before contacting the after-sales service directly or via your dealer, make sure you have observed all instructions and advice in this user manual.

Repairs by the after-sales service, of faults that have occurred because of non-adherence to the information and advice given in this manual have to be charged to the customer and are not covered by your dealer's guarantee.

Attention

The compressor (also known as motor) must not operate continuously.

It is controlled by the thermostat which you set with the temperature control. It switches on automatically when the set temperature in the storage compartment exceeds and switches off automatically when the correct temperature is reached again.

Noise can be heard in every compressor – cooling system when the compressor is switched on. This noise is produced when the motor in the compressor operates and also by refrigerant flowing in the cooling system circuit.

These noises are normal and do not indicate any functional trouble.

In unheated rooms and in cold weather condition condensation can build up on the outer walls of the appliance. This does not mean trouble and disappears when the weather becomes warmer.

Trouble	Possibilities	Check up	Solution	Remarks	
Compressor does not work	Power is off	The fuse is broken	Check the fuse	Replace the fuse	If it is necessary please contact after-sales service for repair
		The connection between plug and socket is not good	Check the socket	Repair or replace the socket	
		The circuit of input and output is out of use	Make sure that the power is on	Check the circuit with electric instrument	
	The thermostat knob is not in the proper position		Check the thermostat	Rotate the thermostat to the proper position	Ask for professional help
Compressor keeps on working	The temperature inside is too high	Frost on the evaporator is too thick	Check whether the frost is thicker than 6-8mm	Defrost regularly	Every 6. month
		The lid is being opened too frequently		Don't open lid so often	3-4 times a day
		Too much food has been stored at once		Take out some of the food	
Too noisy	The floor is not level		Make sure that the Freezer is level	Put pad under the castors	
	The screw in fan or condenser is loose		The screw is loose	Fasten the screw	
	Frysekomponenterne berører hinanden			Separate them	